



Established 1930

Distributors of new & used workshop Equipment

**W680**

**THICKNESSER TH410 16" WOODFAST**

**3HP 240V VARI-FEED DIGI READ**

**OUT ROLLER IN/ OUT FEED**

**INSTRUCTION MANUAL**

**APRIL 2010**

Thicknesser  
TH410

# Instruction Manual

## IMPORTANT

For your safety read instructions carefully before assembling or using this product. Save this manual for future reference.

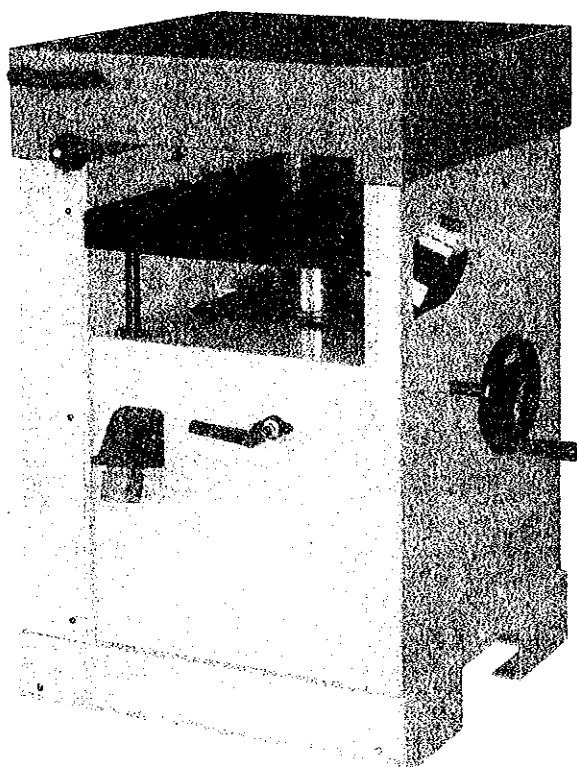

# Index

## 1 GENERAL INFORMATION

### 1.1 Foreword

## 2 MACHINE DESCRIPTION

### 2.1 Machine identification

### 2.2 Getting to know your machine

### 2.3 Technical specification

### 2.4 Recommended protective clothing

### 2.5 Noise emission

### 2.6 Prescribed use of the machine

### 2.7 Hazards

### 2.8 Safety instructions for thicknesser

## 3 INSTALLATION

### 3.1 Lifting and unloading

### 3.2 Position of the machine

### 3.3 Identifying shipping boxes

### 3.4 Installations of loose parts

### 3.5 Electrical connection

### 3.6 Dust chute - Installation

## 4 INSTALLATION AND ADJUSTMENT

### 4.1. Thicknesser table height adjustment

## 5 OPERATING PROCEDURES

### 5.1 ON/OFF switch

### 5.3 Thicknessing

## 6 MAINTENANCE

### 6.1 Replacing cutter knives

### 6.2 Drive Belt Check

## 7 DIAGRAMS & COMPONENTS

# 1. General Information

## 1.1 FOREWORD

This manual must be read and understood before operating the machine. This will provide a better working knowledge of the machine, for increased safety and to obtain the best results.

# 2. Machine Description

## 2.1 MACHINE IDENTIFICATION

There is a metallic identification plate fixed to the machine, containing the manufacturer's data, year of construction, serial number.

## 2.2 GETTING TO KNOW YOUR MACHINE

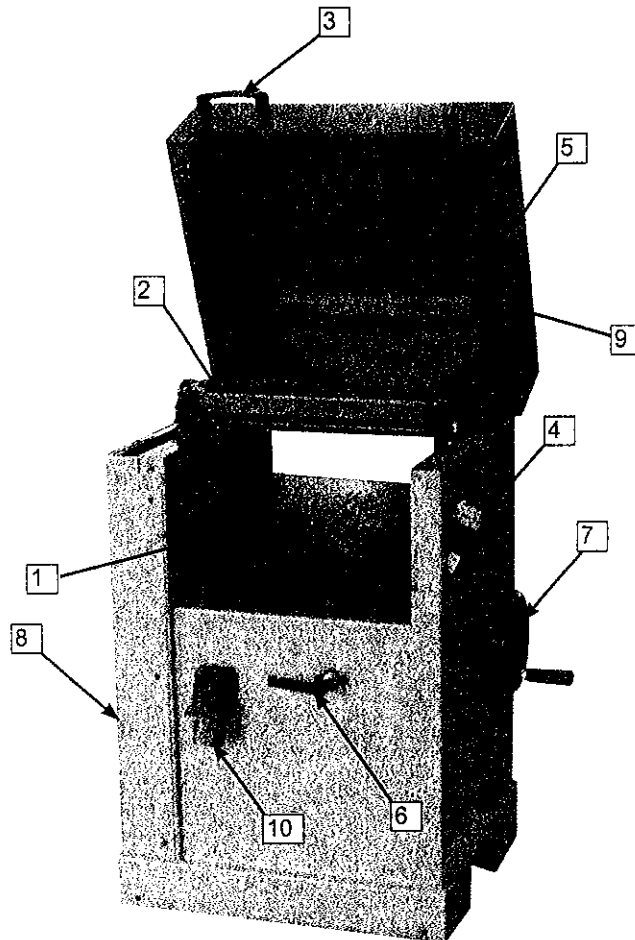

- |   |                   |    |                                   |
|---|-------------------|----|-----------------------------------|
| 1 | Thickness table   | 6  | Locking level                     |
| 2 | Cutterblock guard | 7  | Height setting of thickness table |
| 3 | Opening handle    | 8  | Adjustment handle for feed speed  |
| 4 | On/off switch     | 9  | Dust chute                        |
| 5 | Cover             | 10 | Plug                              |

## 2.3 TECHNICAL SPECIFICATION

SPECIFICATION	TH410
Feed speed m/min	5 to 7
Cutterblock speed rpm	5300
Cutterblock diameter mm	70
Max thicknesser capacity mm	407x225
Max depth of cut thicknesser mm	4
Knives pcs	3
Motor power input	2.75kW
Net Weight kg	170

## 2.4 RECOMMENDED PROTECTIVE CLOTHING

- Non-slip footwear is recommended.
- Do not wear loose clothing, neckties or jewellery; they can be caught in moving parts.
- Roll up long sleeve above the elbow.
- Wear protective hair covering to contain long hair.

## 2.5 NOISE EMISSION

The measurements of noise, in the working position and during operation, were carried out under the standard ISO 7960 Annex B and C:

Instantaneous acoustic pressure:

Sound power level(no load)	<98dB(A)
Sound power level(load)	<107dB(A)
Sound Pressure level(no load)	<89dB(A)
Sound Pressure level(load)	<98dB(A)

Constant K=4 dB measured in accordance with EN ISO 3746:1995

The figures quoted are emission levels and are not necessarily safe working levels. Whilst there is a correlation between the emission and exposure levels, this cannot be used reliably to determine whether or not further precautions are required. Factors that influence the actual level of exposure of the workforce include the characteristics of the work room and the other sources of noise etc. i.e. the number of machines and other adjacent processes. Also the permissible exposure level can vary from country to country. This information, however, will enable the user of the machine to make a better evaluation of the hazard and risk.

## 2.6 PRESCRIBED USE OF THE MACHINE

This machine is intended for surface thickness planing of solid woods. The permissible workpiece dimensions must be observed (see Technical Specification).

Any other use is not as specified. Unspecified use, modification of the machine or use of parts not tested and approved by the equipment manufacturer can cause unforeseen damage.

## 2.7 HAZARDS

**ATTENTION** Thicknesser still present risks that cannot be eliminated by the manufacturer. Therefore the user must be aware that wood working machines are dangerous if not used with care and all safety precautions adhered to.

## 2.8 SAFETY INSTRUCTIONS FOR PLANER.THICKNESSER

A thicknesser is a tool which can, due to operator carelessness, cause serious personal injury. It is therefore strongly recommended you read and observe:

- these instructions, particularly the special safety information in the respective chapters;
- the relevant guidelines or regulations for the prevention of accidents pertaining to the use of thicknessers, where applicable.

Keep all documents, supplied with the machine, for future reference.

The thicknesser shall only be started and operated by persons familiar with thicknessers and who are at any time aware of the dangers associated with the operation of such tool. Persons under 18 years of age shall use this thicknesser only under the supervision of an instructor in the course of their vocational training.

The following residual risks do principally exist with thicknessers and can not, even by employing safety devices, completely eliminated:

**- Hazard generated by environmental conditions:**

do not operate the thicknesser in rain or damp environment. Ensure sufficient lighting. Do not operate the thicknesser near inflammable liquids or gases.

**- Hazard to other persons in the work area:**

Keep bystanders, particularly children, out of the danger zone.

**- Risk of injury by machine faults:**

check the thicknesser for damage before any use. Do not operate the machine with a damaged part. Replace blunt cutter knives at once. Risk of injury by kickback if a blunt knife gets caught in the workpiece's surface.

**- Risk of injury by an unstable stand of the thicknesser:**

when working long stock use suitable supports on both sides of the machine. Avoid adverse body positions. Ensure firm footing, and keep your balance at all times.

**- Risk of injury by foreign objects in the machine:**

prior to any starting of the machine ensure that there are no objects (e.g. tools) in the machine.

**- Risk of injury by workpiece kickback (workpiece is caught by the rotating cutterblock and thrown back against the operator):**

operate machine only with a fully functional anti-kickback lock. Always use sharp cutter knives. If in doubt check workpiece for inclusion of foreign objects (e.g. nails, screws, loose knots).

**- Risk of injury by touching the rotating cutterblock:**

always keep your hands well clear of the cutterblock. Switch machine off and plug out if it is not used.

**- Danger! Drawing-in/trapping hazard!**

Take care that no parts of the body or clothing can get caught and drawn in by the rotating cutterblock (do not wear neck ties and garments with wide sleeves; contain long hair with a hairnet).

**- Risk of injury by cuts with cutterblock at standstill:** Wear gloves when changing cutter knives.

**- Risk of injury by inhaling wood dust:** dust of certain timber species (e.g. oak, beech, ash) can cause cancer when inhaled. Use a suitable dust collector:

- fitting the outer diameter of the suction port (100 mm)

- air volume  $\geq 815$  m<sup>3</sup>/h;

- vacuum at suction port of machine  $\geq 740$  Pa;

- air speed at suction port of machine  $\geq 20$  m/s;

**- Risk of injury by inadequate personal protection:** when planing, wear:

- dust respirator;

- hearing protection;

- safety goggles.

# 3. Installation

## 3.1. LIFTING AND UNLOADING

The machine can be transported by two means:

- with a forklift truck. To do so, the machine is secured on a pallet with four hex bolts.
- by several persons slide the machine from the pallet.

### CAUTION

Do not carry the machine holding it at the infeed and outfeed tables, these are not designed to withstand the tensile load by the machine weight.

## 3.2 POSITION OF THE MACHINE

### CAUTION

It is prohibited to install the machine in explosive environments. Ensure that the floor area around the machine is level, well maintained and free from loose material e.g. chips;

1. Remove four mounting bolts from the machine base.
2. Lift machine off the pallet and set down on the floor.
3. Fix the machine to the floor. Fix the machine feet and fix on ground by means of expansion bolts (not supplied).

## 3.3 IDENTIFYING SHIPPING BOXES

### BEFORE ASSEMBLY

It is advisable that before unpacking to have plenty of paper towels or cloths available to clean off the rust preservative.

## 3.4. INSTALLATIONS OF LOOSE PARTS

The machine is supplied almost assembled. Prior to use, the handwheel must be fitted.

Install the handwheel (A, Fig.4) with set screw (B, Fig.4)

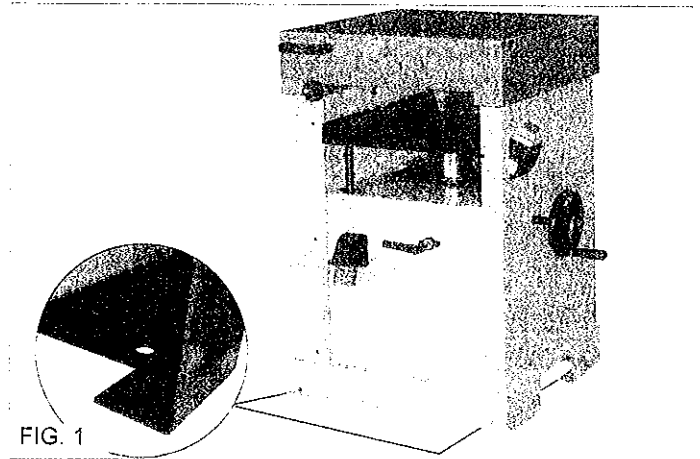

FIG. 1

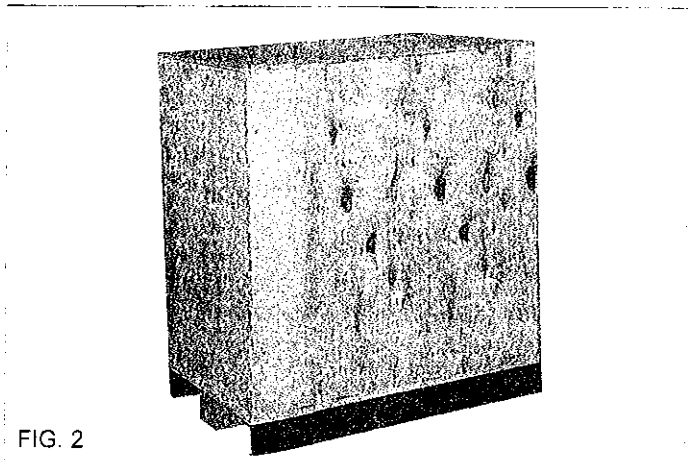

FIG. 2

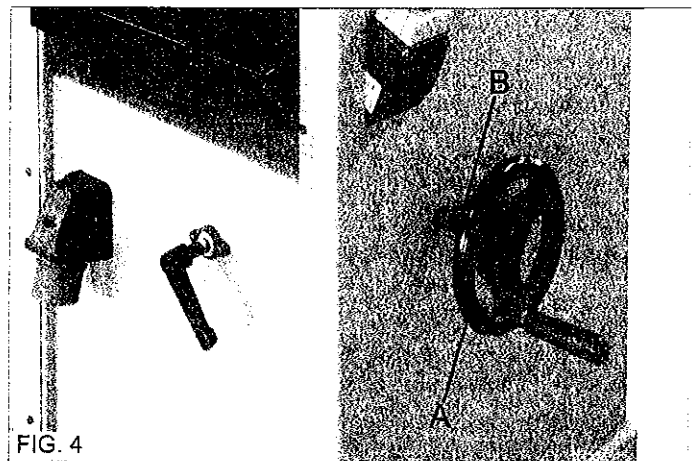

FIG. 4

### 3.5 ELECTRICAL CONNECTION

Electrical installation should be carried out by competent, qualified personnel.

The mains connection should be made using the terminal box.

Ensure that the mains supply corresponds with that of the machine, use cables of a section suitable for the power of the motor. For a supply tension of 400 V the minimum section recommended is 2.5 mm, including the earth wire.

For a mains supply of 230 V or a power rating greater than 15 A it will be necessary to increase the section of the connecting cables .

Connect the phase wires to the terminals R - S - T (L1 - L2 - L3) and the earth wire to the earth terminal.

On initial start-up check the direction of rotation, if it is incorrect then invert the two phase wires (for machines with 3 phase supply).

Direction of rotation of machines with single-phase supply is pre-determined during production .

On completion of the installation check that the terminal box is closed correctly and that the plug points are locked.

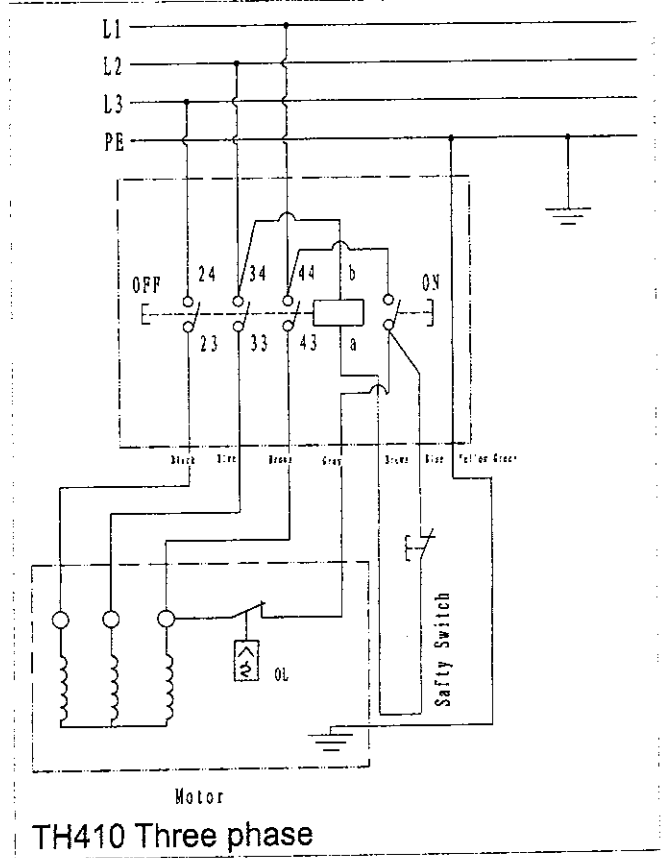
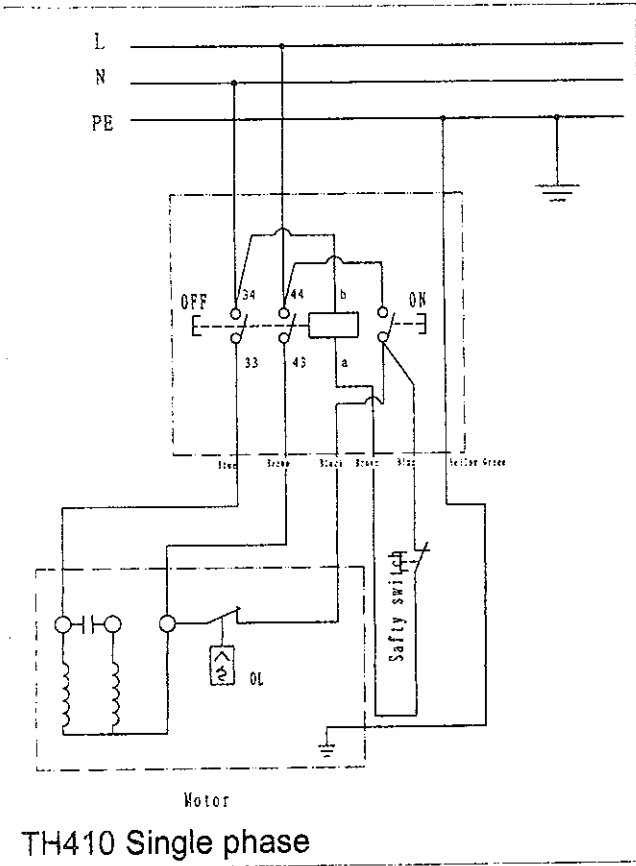

### 3.6. DUST CHUTE - INSTALLATION

The dust chute complete with suction connector must be installed for thickness planing.

Connect a suitable dust collector to the suction connector of the planer/thicknesser.

# 4. Adjustment

## 4.1. THICKNESSER TABLE HEIGHT ADJUSTMENT

With the height setting for the thicknesser bed the planing thickness (= thickness of the workpiece after planing) is set when the machine is used for thickness planing.

Per pass a maximum of 4 mm material can be removed.

Workpieces of max. 200 mm thickness can be planed. Height adjustment is made with a handwheel (A, Fig.10). One full turn of the handwheel changes the height of the thicknesser bed (B, Fig.10) by 4 mm.

Clockwise turning = raises the thicknesser bed

Counter-clockwise turning = lowers the thicknesser bed. The set planing thickness is indicated on the scale (C, Fig.10).

- When the height is settled, locking the table with locking lever (D, Fig.10)

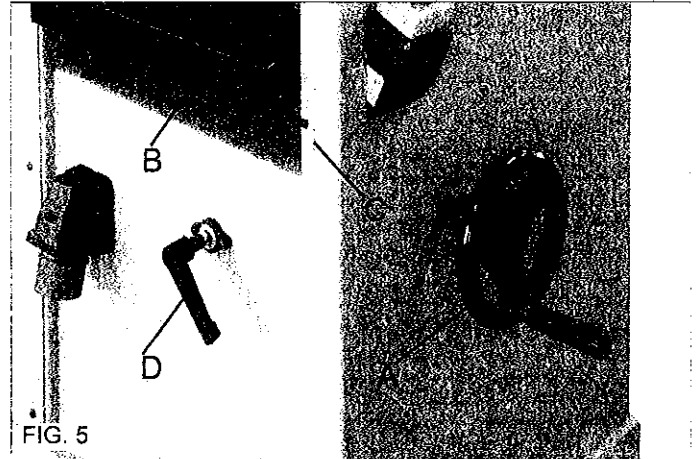

# 5. Operating Procedures

## 5.1. ON/OFF SWITCH (Fig.13)

To switch ON = press green switch button.

To switch OFF = close cover or press red switch button.

To unlock the switch cover push the pin on the stop cover.

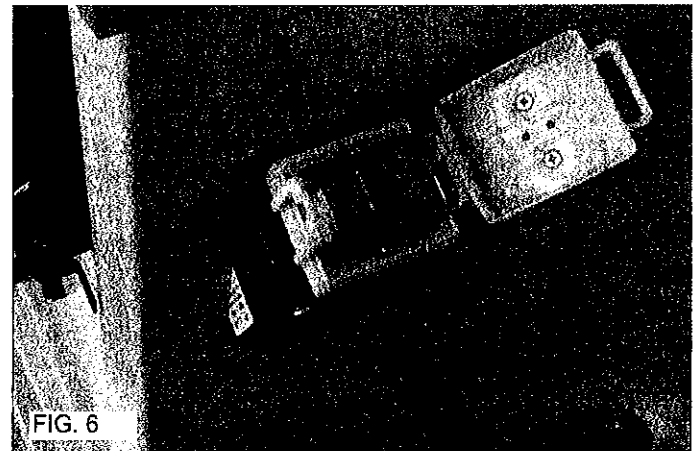

## 5.2. THICKNESSING

Note: Thickness planing is used to reduce a workpiece with one already surface planed surface to a desired thickness.

- The workpiece is run through the thicknesser.
- The surface already planed flat rests on the thicknesser bed.
- The workpiece is cut on the upper side.
- The feed direction of the workpiece is exactly opposite than with surface planing.

Workpiece dimensions

- Length: min. 200 mm; for workpieces over 1500 mm use a second person for support.
- Width: max. 407 mm.
- Thickness: min 6 mm; max. 200 mm.

Note: The max. depth of cut for a single pass is 4 mm.

1. Assume proper operating position:

- to feed the workpiece into the machine, position yourself offset to one side of the feed opening.

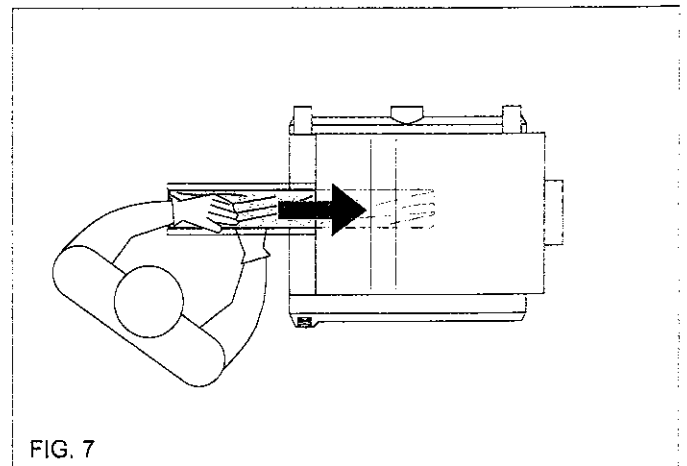

- to remove the workpiece from the machine, position yourself offset to one side of the outfeed opening.
- 2. To thickness plane stock which surfaces are not parallel, use suitable feeding aids (make fitting templates).
- 3. Set planing thickness.
- 4. Start motor.
- 5. Feed workpiece slowly and straight into the thicknesser. It will then be automatically fed through the thicknesser.
- 6. Guide workpiece straight through the thicknesser.
- 7. Switch machine off if no further cutting is to be done immediately afterwards.

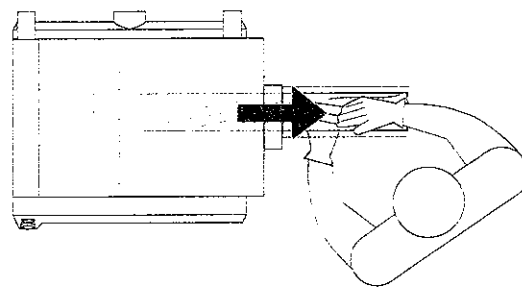

FIG. 8

### 5.3. FEED SPEED CHANGE

The feed speed of this machine can be adjusted by the handle (A, Fig.9).

- Start the motor
- Turn the handle clockwise, the feed speed will be increased.
- Turn the handle anti-clockwise, the feed speed will be decreased.

Note: The feed speed changing handle only can be operated when the motor is started.

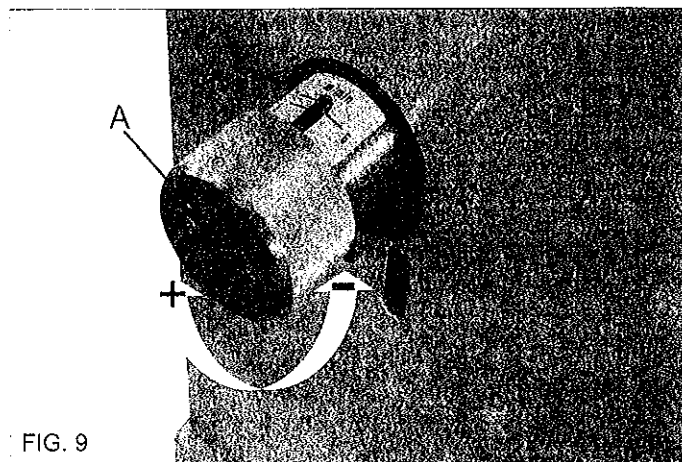

FIG. 9

# 6. Maintenance

## 6.1 REPLACING CUTTER KNIVES

**CAUTION!** Risk of personal injury by cuts from the cutter knives!  
Wear gloves when changing cutter knives.

To remove the cutter knives:

1. Unplug power cable.
2. Open the cutterblock cover.
3. Turn the five hexagon head screws of the cutter knife lockbar fully in wear gloves! (Fig.10).
4. At first remove cutter knife, then cutter knife lockbar from the cutterblock.
5. Clean all surfaces of cutterblock and cutter knife lockbar with a suitable solvent.
6. Place fresh cutter knife on cutter knife lockbar.
7. Place cutter knife lockbar with the fitted cutter knife into the cutterblock.
8. Check the projection of the knives:
  - With the provided straight edge gauge .
  - Place straight edge gauge across outfeed table and cutterblock as shown.
  - Turn cutterblock by hand one turn against the direction of feed.
  - The cutter knives are set correctly if the straight edge is moved forward 4 to 6 mm by the turning cutterblock. This check must be performed at both ends of the cutterblock. (Fig.11)
9. To tighten the cutter knives, turn the five hexagon head screws of the cutter knife lockbar fully out. To prevent distortion of the cutter knife lockbar start with the screws in the centre , then tighten the screws closer to the edges step by step.(Fig.12)

**Danger!**

- Do not extend tool when tightening the screws.
- Do not tighten bolts by striking the wrench.

10. Return cutterblock cover to its starting position.
11. Pull fence forward.

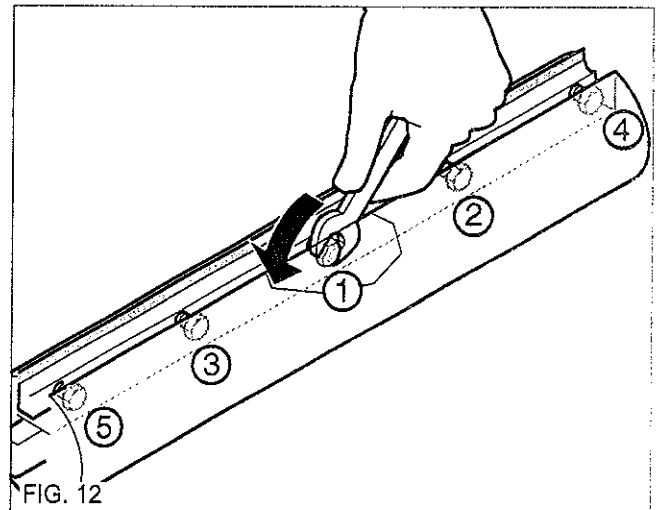
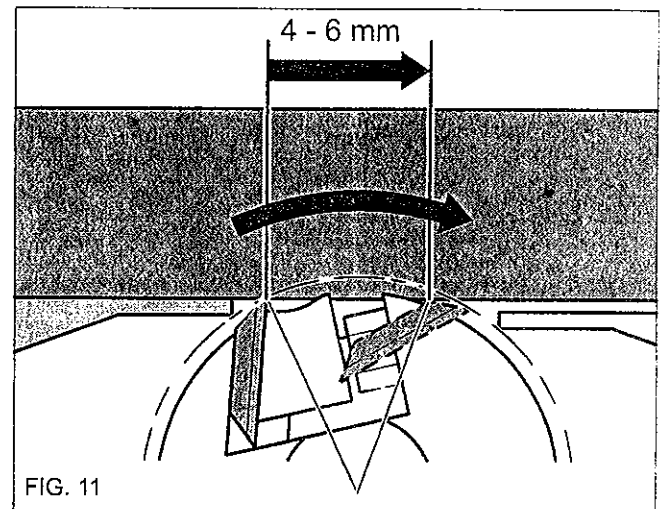
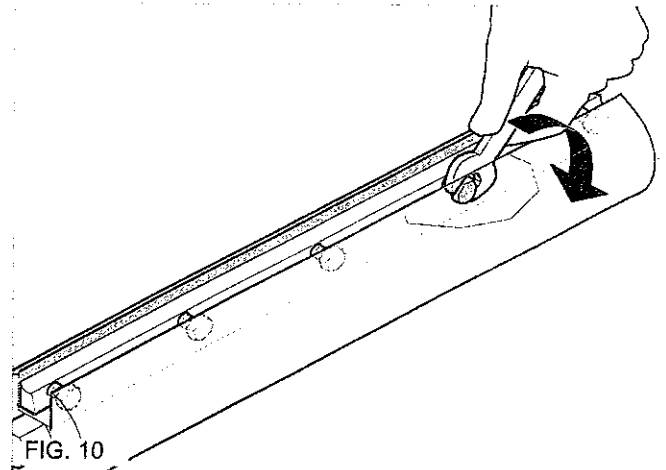

## 6.2 Drive Belt Check

The cutterblock drive belt and the feedgear drive belt need to be checked periodically and retightened if necessary. Both drive belts are located behind the machine's side panel.

Checking the drive belt:

1. Unplug power cable.
2. Take off the the side panel and open the cutterblock cover (A, Fig.13)
3. Check belt tension with thumb pressure. The drive belt should not give more than 10 mm in the centre.

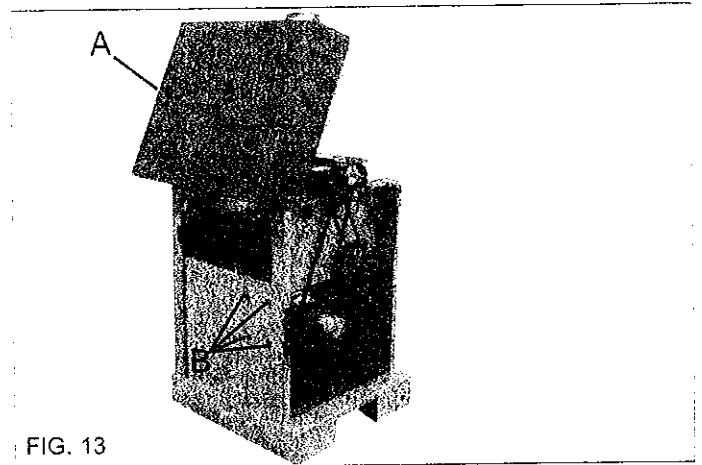
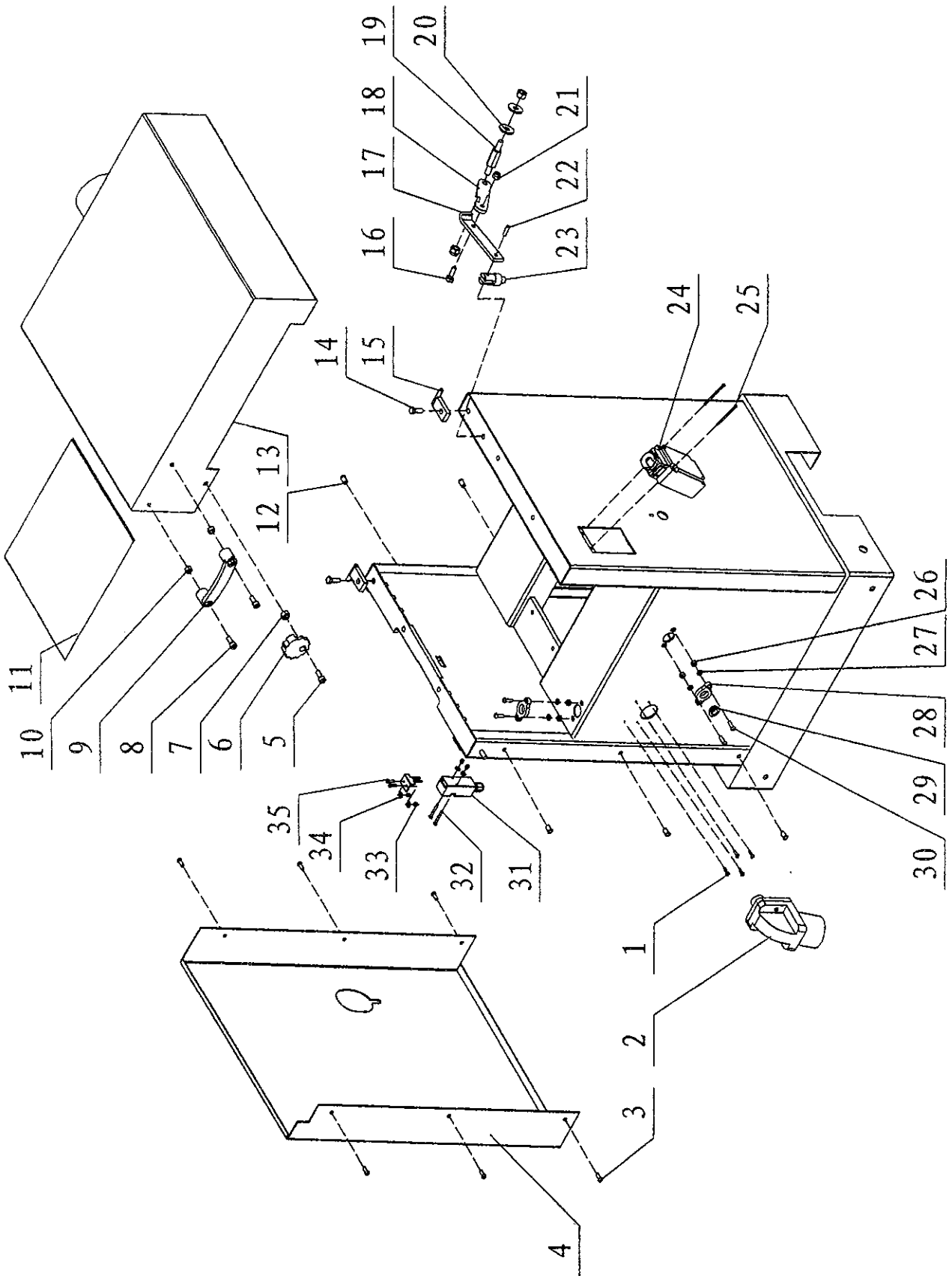

FIG. 13

Tensioning the drive belt:

4. From outside the machine, loosen the four nuts (B, Fig.13) and lift the motor to slacken the drive belt.
5. To tension the cutterblock drive belt, push the motor downward. When belt tension is correct tighten motor mounting nuts (B, Fig.13).
6. If necessary, remove chips and dust with dust collector or brush.
7. Replace the side panel and belt cover secure with the screws.

# 7. Diagrams & Components



Ref No.	Description
1	Pan head screw M4X8
2	Plug
3	Set screw M6X16
4	Rear panel
5	Screw M10X25
6	Lock knob
7	Lock nut M10
8	Screw M8X30
9	Handle
10	Lock nut M8
11	Insulative foam
12	Nut M6X15
13	Upper cover
14	Hex bolt M10X25
15	Bracket
16	Hex bolt M6X20
17	Support bracket I
18	Support bracket II

Ref No.	Description
19	Shaft
20	Flat washer 8
21	Lock nut M6
22	Roll pin 5x16
23	Support shaft
24	Switch
25	Pan head screw M4X60
26	Hex nut M6
27	Flat washer 6
28	Spacer
29	Tube
30	Set screw M6X20
31	Safety switch
32	Pan head screw M4X35
33	Lock nut M4
34	Flat washer 4
35	Pan head screw M4X16

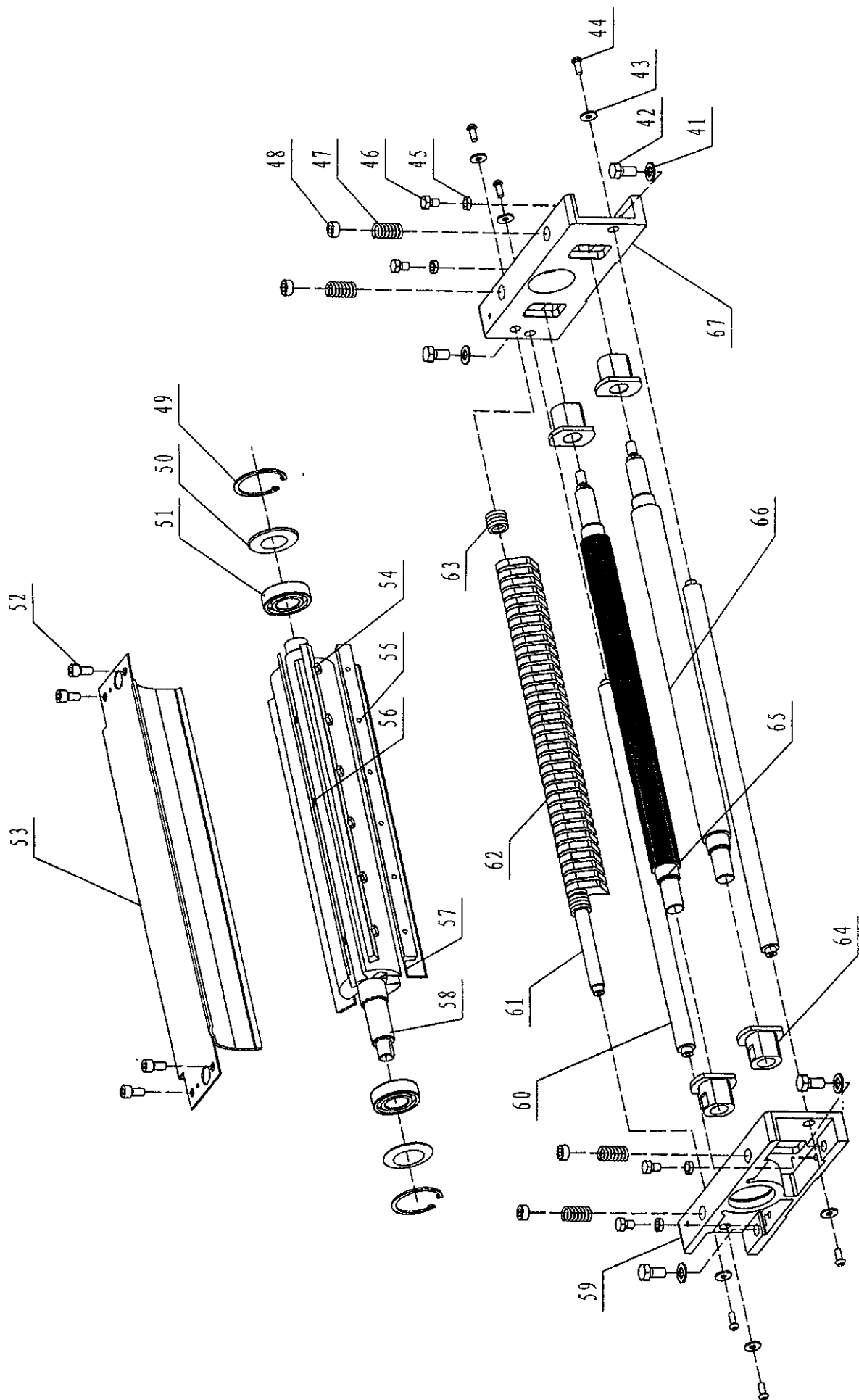

Ref No.	Description
41	Flat washer 10
42	Hex bolt M10X25
43	Flat washer 6
44	Screw M6X12
45	Hex nut M8
46	Hex bolt M8X12
47	Spring
48	Screw
49	Retaining ring
50	Wave washer 52
51	Bearing 6205
52	Set screw M6X12
53	Cutterblock cover
54	Square head screw

Ref No.	Description
55	Locking bar
56	Spring
57	Knife
58	Cutter block
59	Cutterblock bracket-left
60	Support rod
61	Anti-kickback shaft
62	Anti-kickback finger
63	Adjusting washer
64	Tube
65	Infeed roller
66	Outfeed roller
67	Cutterblock bracket-right

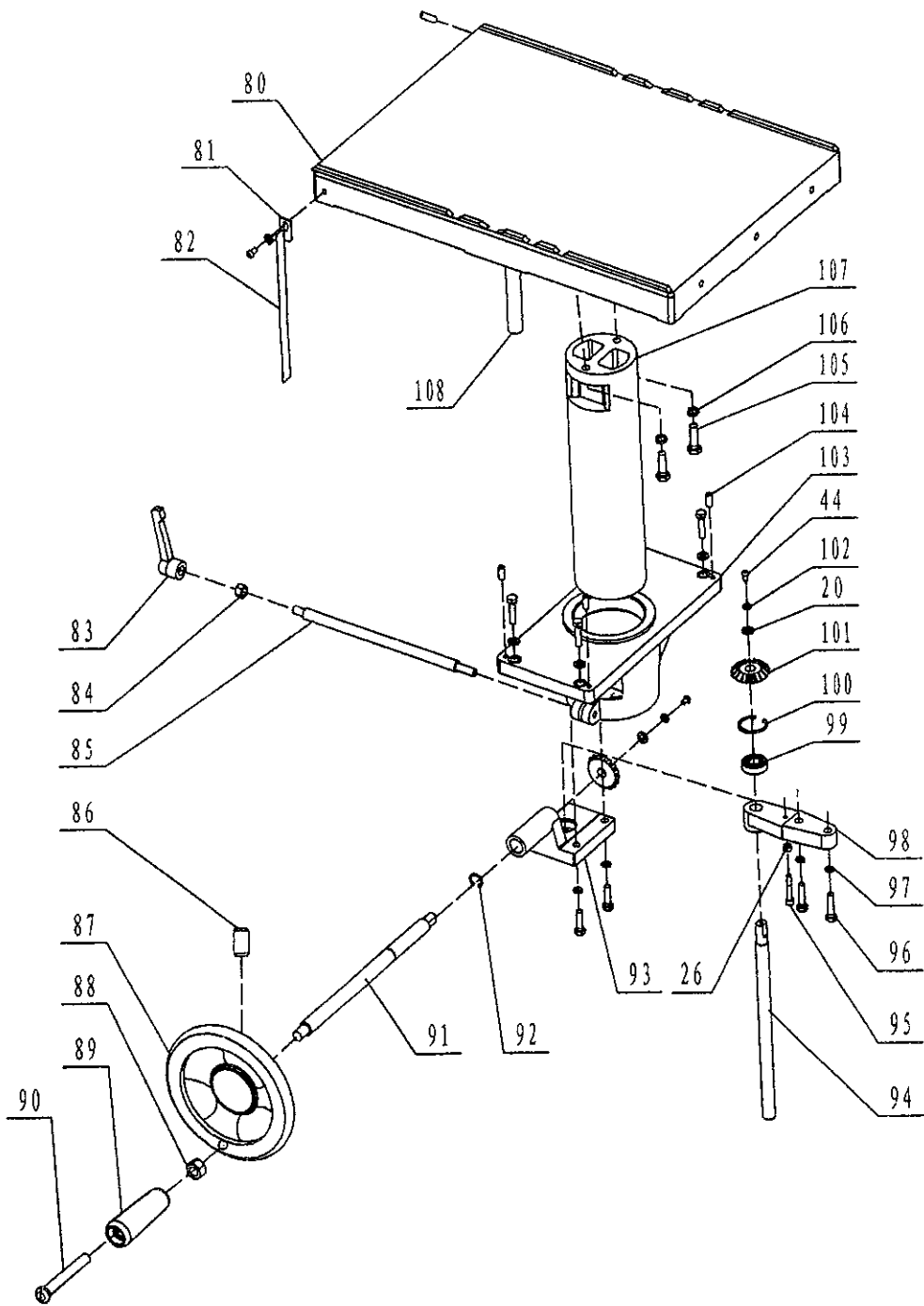

Ref No.	Description
80	Thickness table
81	Indicator
82	Scale
83	Lock handle
84	Hex nut M10
85	Locking bar
86	Screw M8X16
87	Crank handwheel
88	Hex nut M10
89	Handle
90	Handle bolt
91	Crank bar
92	Retaining ring
93	Bevel gear bracket
94	Thread rod

Ref No.	Description
95	Screw M6X40
96	Hex bolt M8X35
97	Spring washer
98	Thread rod bracket
99	Bearing 80202
100	Retaining ring 35
101	Bevel gear
102	Flat washer 6
103	Column support
104	Set screw M8X20
105	Hex bolt M10X35
106	Spring washer 10
107	Column
108	Guide bar

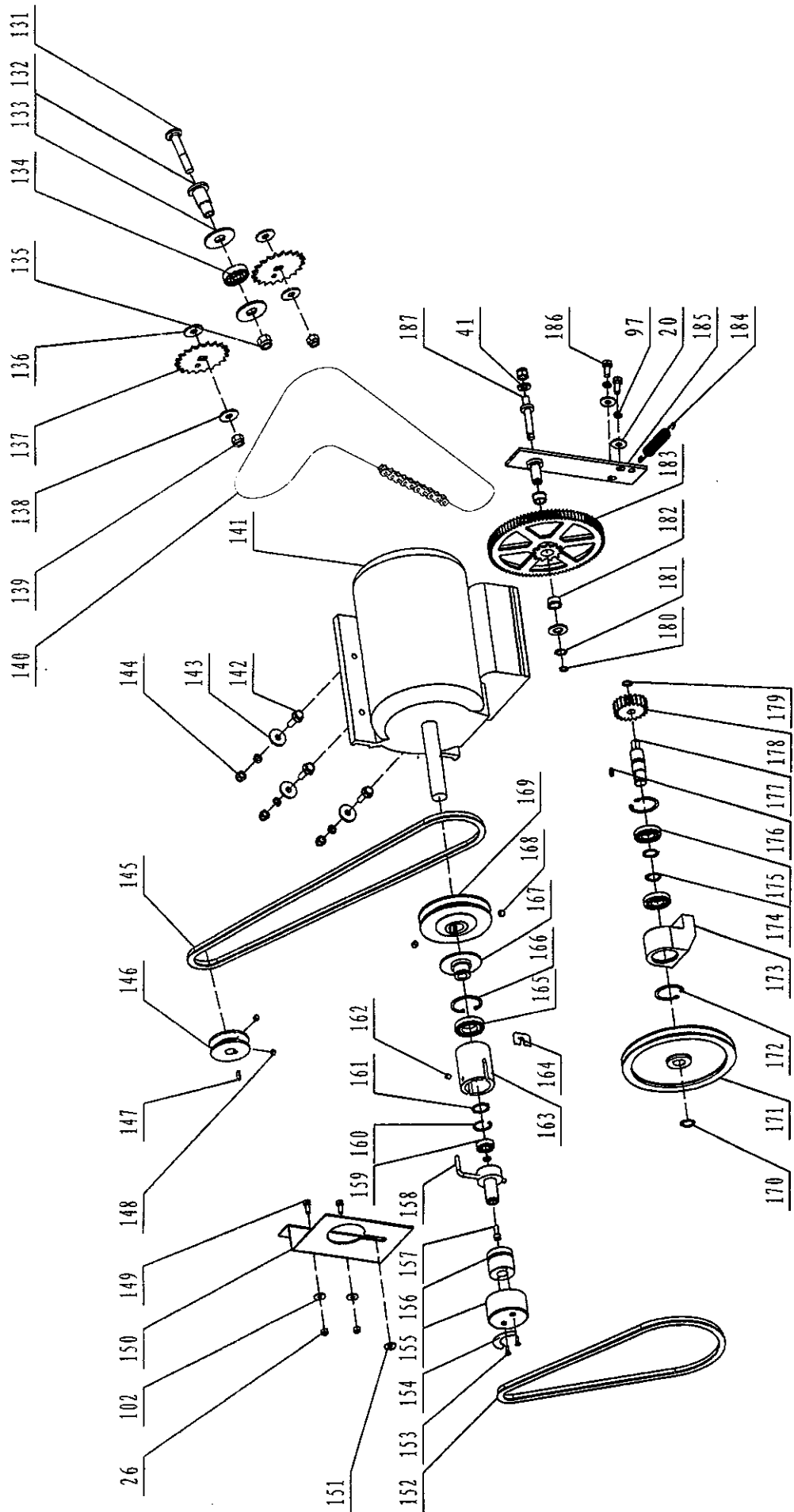

Ref No.	Description
131	Carriage bolt M12X70
132	Tube
133	Flat washer 16
134	Bearing 80203
135	Hex nut M12
136	Washer
137	Chain wheel
138	Flat washer 10
139	Lock nut M10
140	Chain
141	Motor
142	Flange bolt M8X25
143	Flat washer 8
144	Cap nut M8
145	Dentiform belt
146	Spindle pulley
147	Key 6x16
148	Set screw M8X6
149	Hex bolt M6X16
150	Panel
151	Cable tube
152	Dentiform belt
153	Pan head screw
154	Rotation scale
155	Adjusting knob
156	Adjusting nut
157	Hex socket head screw
158	Position bar
159	Bearing 80101

Ref No.	Description
160	Retaining ring 28
161	Retaining ring 25
162	Set screw M6X8
163	Tube
164	Scale
165	Bearing 6005
166	Retaining ring 47
167	Sliding pulley
168	Set screw M8X8
169	Motor pulley
170	Retaining ring 18
171	Pulley
172	Retaining ring 42
173	Bearing seat
174	Retaining ring 20
175	Bearing 80104
176	Key 4x12
177	Pulley shaft
178	Small gear
179	Retaining ring 12
180	Retaining ring 10
181	Retaining ring 15
182	Pulley tube
183	Pulley
184	Spring
185	Wheel bracket
186	Hex bolt M8X20
187	Pulley shaft